

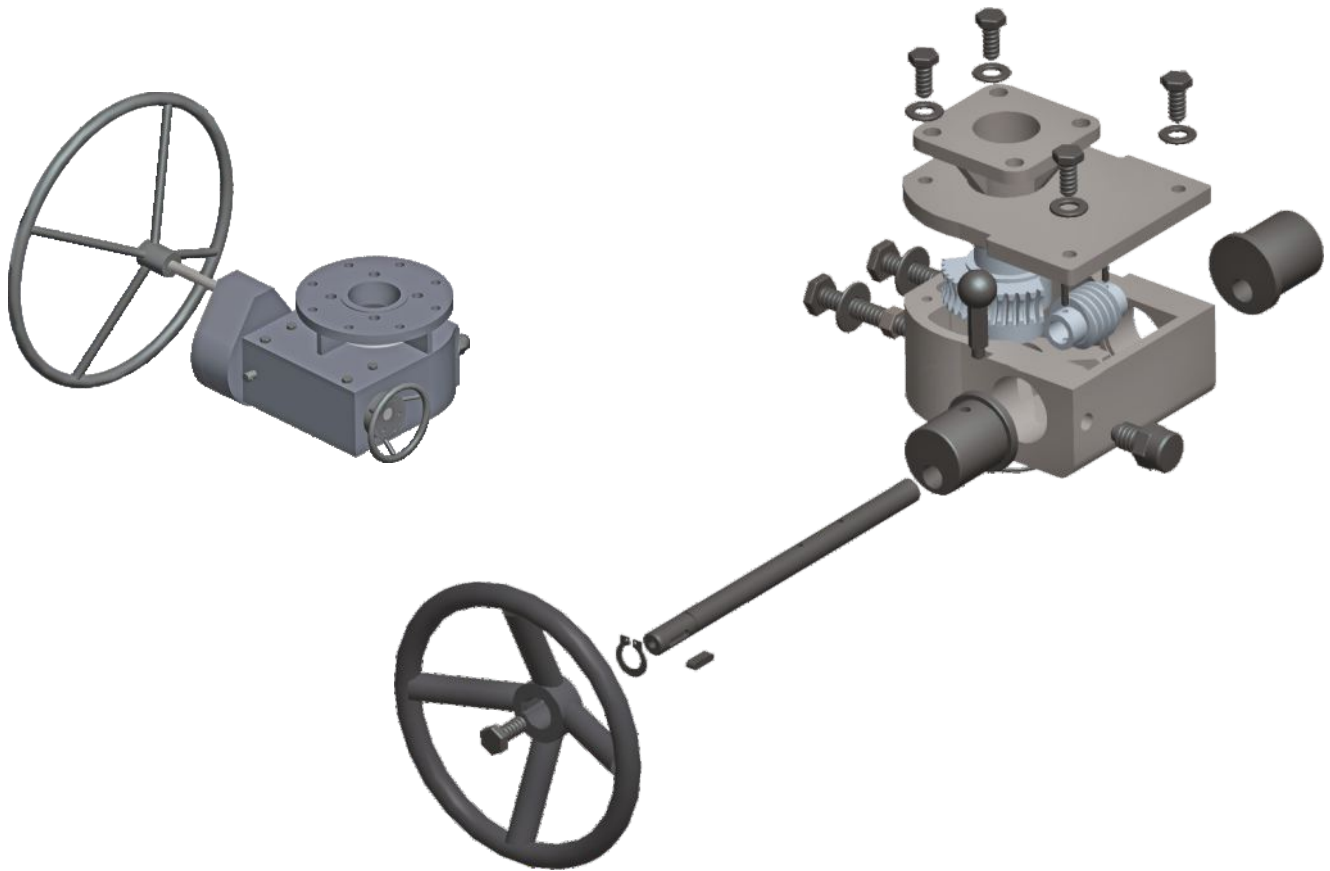

## 612 Series Manual Override Gear Operators



### # 612 Series MOR

- The Q-Tork 612 series Manual Override (MOR) are designed and used for manually overriding pneumatic actuators mainly for industrial application
- The compact robust designed product has optimum ratio to reduce efforts during its operation

### Application

- The 612 series MOR are widely used for its reliability where their are double acting and spring return pneumatic actuators
- All MOR are mounted between the valve and actuator

### Features and Benefits

- Cast iron housing and cover
- High performance axial bearing
- Light weight with rugged design
- Rim efforts as per DIN EN-12570 Standard
- Maintenance free
- Temperature range -30°C to 120°C
- Epoxy premier coated housing and cover
- Environmental friendly high performance grease

### Optional

- Housing materials - carbon steel, stainless steel, ductile iron
- Submersibility to IP-67
- Stainless steel - shaft, handwheel and hardware

**Dimensional Specifications**

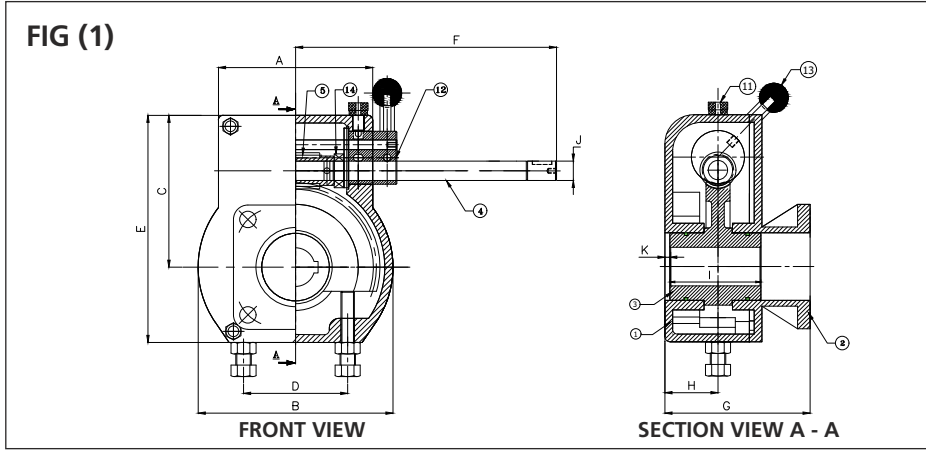

Sr. No.	Models	A	B	C	D	E	F	G	H	I	J	K
1	QTM-100	89	72	66	40	93	119	86.5	32	47.5	10	2
2	QTM-250	106	98	81	44	121	215	86	28.5	50	12	2
3	QTM-450	115	132	97.5	70	142.5	165	123	41	73	15	2
4	QTM-750	117	125	109	70	165	185.5	123	45	72.5	20	2
5	QTM-1000	154	180	120.5	95	185.5	190	148.5	59	112.5	20	4
6	QTM-1500	160	202	157.5	108	235.5	230	150.5	55	94.5	20	5
7	QTM-2500	204	218	165	108	250	237	171	66	122	20	6
8	QTM-3500	185	296	203	150	351	265	195	78	128	20	7

**Standard Stem Shape and Orientation as seen from top view worm wheel at close position**

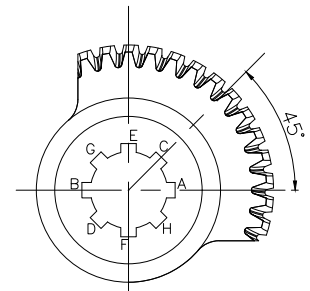

**ROUND**

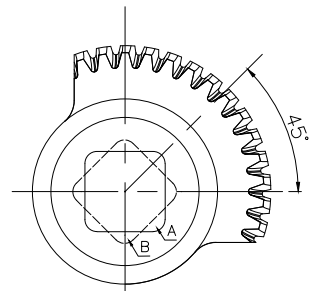

**SQUARE**

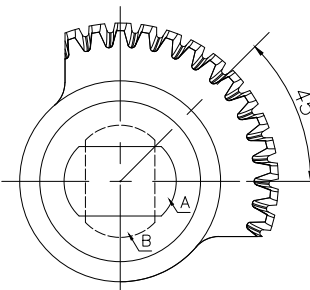

**DOUBLE - D**

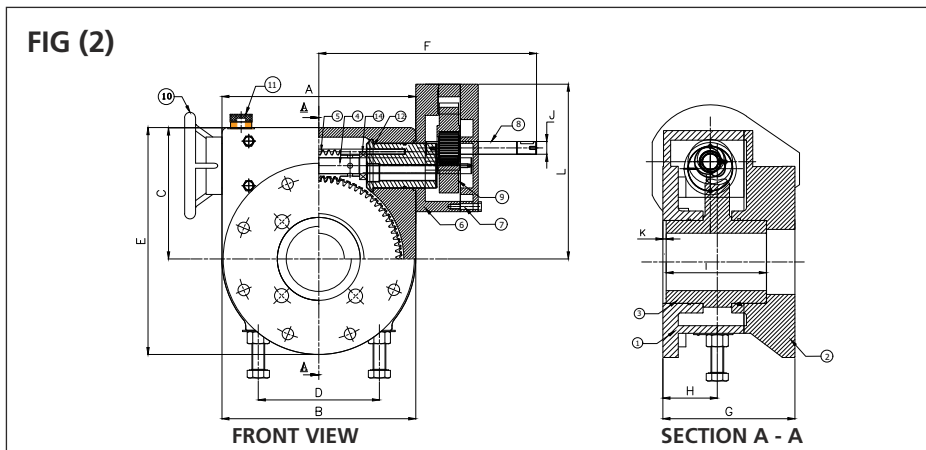

Sr. No.	Models	A	B	C	D	E	F	G	H	I	J	K	L
9	QTM-5000/ MR1	304	304	206	190	356	341.5	207	85.3	156	20	6	274
10	QTM-7500/ MR2	304	326	235	190	385	341.5	225	89.3	167	20	4	340
11	QTM-10000/ MR2	362	367	367	210	440	370	242	98	198.5	20	6	362.5
12	QTM-15000/ MR3	400	403	282	228	483.5	389.5	243	108	211	20	6.5	400
13	QTM-35000/ MR4	460	510	360	300	597	554.5	337	123	292	25	8	438



## Handwheel Specification: For Keyway / Pin-hole

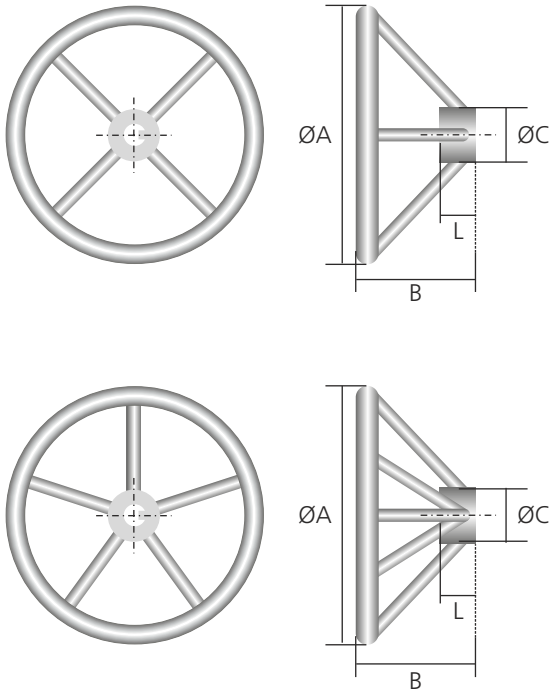

Sr. No	Hand-wheel Dia A	Height B	Bush OD Dia C	Bush Length L	No. of Spokes
1	110	62.5	22	30	3
2	200	80	25	25	4
		50	35	35	3
3	250	80	40	30	4
			30	25	
4	300	100	40	30 / 25	4
		75	45	50	3
5	350	110	40	30	4
		100	30	25	
6	400	130	50	30	4
7	450	145	50	30	4
8	500	110	65	30	4
9	550	120	65	30	4
10	600	130	65	30	5
11	650	140	65	30	5
12	700	150	65	30	5
13	750	160	65	30	5
			50	50	5
14	800	160	65	30	5
15	900	160	65	30	5
16	1000	165	65	50	5
17	1000	165	65	50	5

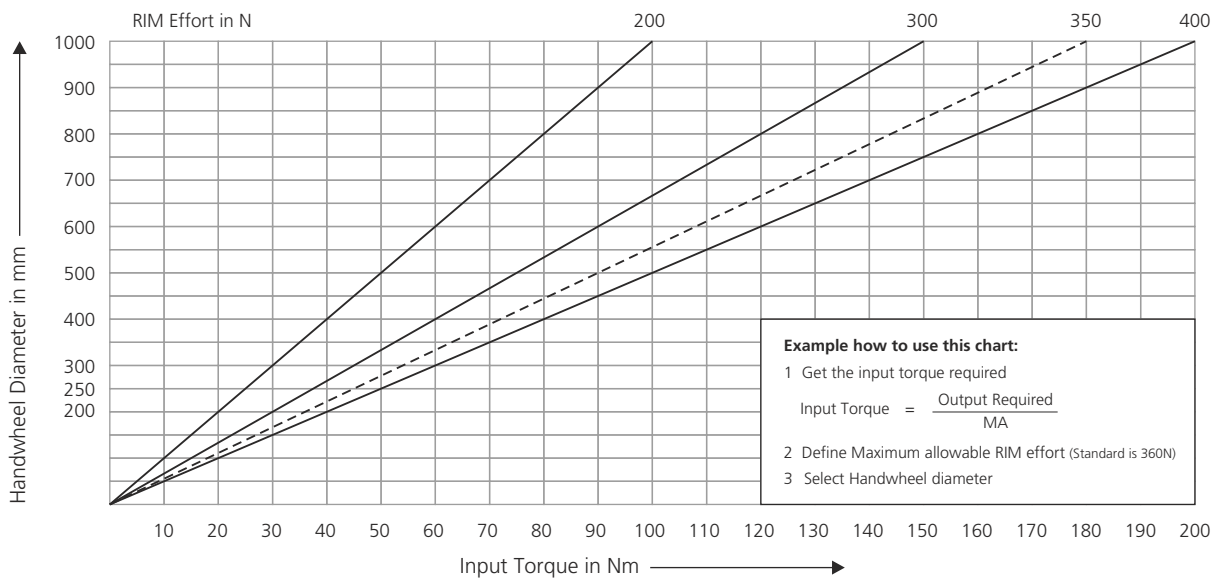

The information & specifications of this literature is believed to be accurate. It is supplied for informative purpose only and shall not be considered as guarantee or certificate for satisfactory result. As a part of continual improvement in its product design, specification and dimension is subject to change without notice. Should there be any question concerning this leaflet, the buyer / user should get in touch with **Q-Tork Automation Pvt. Ltd.** at any of its office locally / worldwide.

## Q-Tork Automation Pvt. Ltd.

Manufacturers of:

- Quarter-turn Worm Gear Operators • Manual Override Gear Operators
- Quarter-turn Worm Gear Operators for Electrical Actuation • Multi-turn Bevel Gear Operators
- Quarter-turn Worm Gear Operators with Spline Bush • Multi-turn Worm Gear Operator with Spline Bush



**Works :** Gat No # 1083/1B, Markal, Tal. - Khed, Pune - 412 105. Maharashtra, INDIA.

• cellular # +91 99 22 009715 • email # marketing@qtork.com • [www.qtork.com](http://www.qtork.com)

